

QT025

Liquid Cooled Gas Engine Generator Sets

Standby Power Rating
25 kW 60 Hz



GENERAC 1.6L ENGINE

Naturally Aspirated
Gaseous Fueled
Meets 2009 EPA Emission Regulations

STANDARD EQUIPMENT

- All input connections in one single area
- High coolant temperature shutdown
- Low oil pressure shutdown
- Low coolant level automatic shutdown
- Overspeed automatic shutdown
- Crank timer
- Exercise timer
- Oil drain extension
- Cool flow radiator
- Closed coolant recovery system
- UV/Ozone resistant hoses
- Watertight state of the art electrical connectors
- Mainline circuit breaker
- Radiator drain extension
- Battery charge alternator
- 2 Amp static battery charger
- Battery cables
- Battery rack
- Fan and belt guards
- Isochronous governor

FEATURES

- Innovative design and fully prototype tested
- UL2200 Listed
- Solid state frequency compensated voltage regulator
- Dynamic and static battery charger
- Sound attenuated acoustically designed enclosure
- Quiet test for low noise level exercise
- Acoustically designed engine cooling system
- High flow low noise factory engineered exhaust system
- State of the art digital control system with R100 digital control panel
- Watertight electrical connectors
- Rodent proof construction
- High efficiency, low distortion Generac designed alternator
- Vibration isolated from mounting base
- Matching Generac transfer switches engineered and tested to work as a system
- All components easily accessible for maintenance
- Electrostatically applied powder paint

GENERAC®

GENERATOR SPECIFICATIONS

TYPE	Synchronous
ROTOR INSULATION.....	Class F
STATOR INSULATION.....	Class F
TOTAL HARMONIC DISTORTION.....	<5%
TELEPHONE INTERFERENCE FACTOR (TIF)	<50
ALTERNATOR OUTPUT LEADS 3 PHASE	4 wire
BEARINGS.....	Sealed Ball
COUPLING.....	Flexible Disc
LOAD CAPACITY (STANDBY RATING).....	25 kW
EXCITATION SYSTEM.....	Direct

NOTE: Generator rating and performance in accordance with ISO8528-5, BS5514, SAE J1349, ISO3046, and DIN6271 standards.

VOLTAGE REGULATOR

TYPE	Electronic
SENSING	Single Phase
REGULATION.....	± 1%
FEATURES.....	V/F Adjustable Adjustable Voltage and Gain LED Indicators

GENERATOR FEATURES

- Revolving field heavy duty generator
- Directly connected to the engine
- Operating temperature rise 120 °C above a 40 °C ambient
- Insulation is Class F rated at 130 °C rise
- All models are fully prototyped tested

CONTROL PANEL FEATURES

- | | |
|--|---|
| <input type="checkbox"/> SEVEN LED INDICATOR LIGHTS <ul style="list-style-type: none">• System ready• Low fuel pressure• Low battery• Low oil pressure• High coolant temp/low coolant temp• Overspeed• Overcrank | <input type="checkbox"/> ADDITIONAL FUNCTIONS <ul style="list-style-type: none">• Utility sensing• Delay on utility failure for engine start• Engine warm-up before transfer• Delay to retransfer to utility• Engine cooldown timer• Exerciser not set |
|--|---|
-
- INTERNAL FUNCTIONS:
 - 3 position switch (auto, off and manual)
 - 2 wire start for any transfer switch
 - Communicates with the Generac RTS transfer switch
 - Built-in 7 day exerciser
 - Selectable engine speed at exercise
 - Governor controller is built into the master control board
 - Temperature range -40 °C to 70 °C

ENGINE SPECIFICATIONS

MAKE	Generac
MODEL.....	In line
CYLINDERS.....	4
DISPLACEMENT.....	1.6 Liter
BORE	3.15
STROKE.....	3.13
COMPRESSION RATIO.....	9.75:1
INTAKE AIR SYSTEM.....	Naturally Aspirated
VALVE SEATS	Replaceable
LIFTER TYPE.....	Hydraulic

GOVERNOR SPECIFICATIONS

TYPE	Electronic
FREQUENCY REGULATION.....	Isochronous
STEADY STATE REGULATION.....	± 0.25

ENGINE LUBRICATION SYSTEM

OIL PUMP	Gear
OIL FILTER.....	Full flow spin-on cartridge
CRANKCASE CAPACITY.....	4 Quarts

ENGINE COOLING SYSTEM

TYPE	Closed
WATER PUMP.....	Belt driven
FAN SPEED	2550
FAN DIAMETER.....	15 inches
FAN MODE.....	Pusher

FUEL SYSTEM

FUEL TYPE	Natural gas, propane vapor
CARBURETOR.....	Down Draft
SECONDARY FUEL REGULATOR.....	Standard
FUEL SHUT OFF SOLENOID	Standard
OPERATING FUEL PRESSURE.....	.5" - 14" H ₂ O

ELECTRICAL SYSTEM

BATTERY CHARGE ALTERNATOR.....	12V 30 Amp
STATIC BATTERY CHARGER	2 Amp
RECOMMENDED BATTERY	Group 26, 525CCA
SYSTEM VOLTAGE.....	12 Volts

QT025

OPERATING DATA

		QT025		
KW RATING		25		
ENGINE SIZE		1.6 Liter 4 cyl. inline		
GENERATOR OUTPUT VOLTAGE/KW - 60Hz		KW	AMP	CB Size
120/240V, 1-phase, 1.0 pf		25	104	125
120/208V, 3-phase, 0.8 pf		25	87	100
120/240V, 3-phase, 0.8 pf		25	75	90
GENERATOR LOCKED ROTOR KVA AVAILABLE @ VOLTAGE DIP OF 35% Single phase or 208/240 3-phase		34		
ENGINE FUEL CONSUMPTION (Natural Gas) (Propane)		Natural Gas	Propane	
		(ft ³ /hr.)	(gal/hr.)	cu ft/hr
Exercise cycle		60	0.65	24
25% of rated load		161	1.76	64
50% of rated load		253	2.77	101
75% of rated load		345	3.79	138
100% of rated load		437	4.81	175
ENGINE COOLING				
Air flow (inlet air including alternator and combustion air)		ft ³ /min.	1,528	
System coolant capacity		US gal.	2.0	
Heat rejection to coolant		BTU/hr.	110,000	
Max. operating air temp. on radiator		°C (°F)	60 (150)	
Max. ambient temperature		°C (°F)	50 (140)	
COMBUSTION AIR REQUIREMENTS				
Flow at rated power 60 Hz		cfm	90	
SOUND EMISSIONS IN DBA				
Exercising at 7 meters		62		
Normal operation at 7 meters		74		
EXHAUST				
Exhaust flow at rated output 60 Hz		cfm	249	
Exhaust temp. at muffler outlet		°F	1015	
ENGINE PARAMETERS				
Rated synchronous RPM		60 Hz	3600	
HP at rated KW		60 Hz	45	
POWER ADJUSTMENT FOR AMBIENT CONDITIONS				
Temperature Deration				
3% for every 10 °C above - °C		25		
1.65% for every 10 °F above - °F		77		
Altitude Deration				
1% for every 100 m above - m		183		
3% for every 1000 ft. above - ft.		600		

RATING: All three phases units are rated at 0.8 power factor. All single phase units are rated at 1.0 power factor. STANDBY RATING: Standby ratings apply to installations served by a reliable utility source. The standby rating is applicable to varying loads for the duration of a power outage. There is no overload capability for this rating. Ratings are in accordance with ISO-3046-1. Design and specifications are subject to change without notice.

KW rating is based on LPG Fuel and may derate with natural gas.

C1 Enclosure 18, 20, 25, 30 kW 1.6 Liter QT

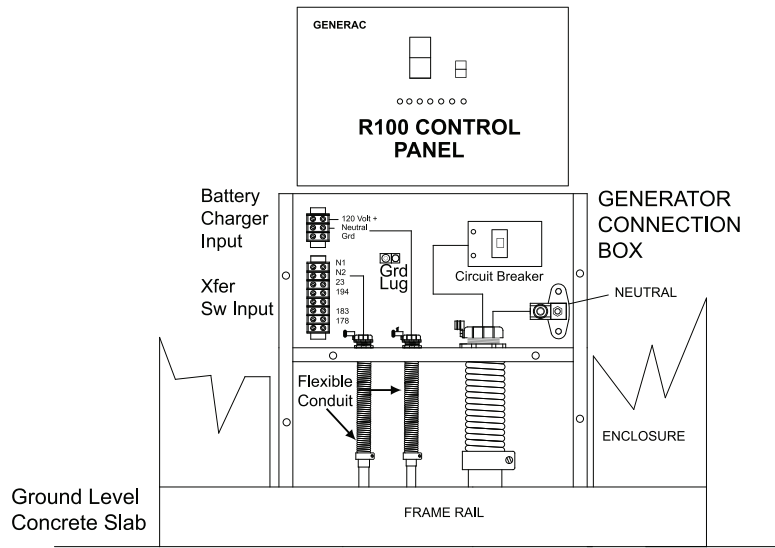

Installation Drawing Ref. No. 0G5116

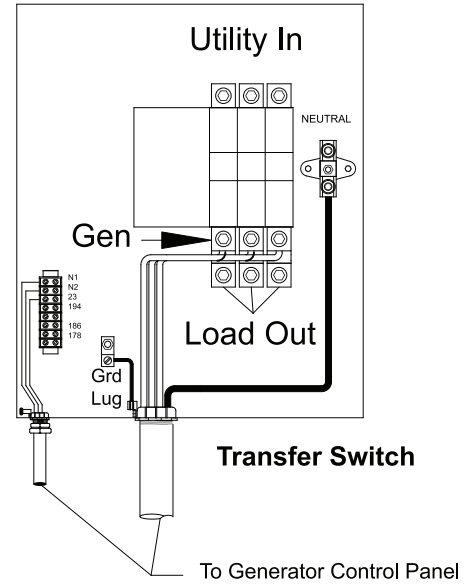

CIRCUIT BREAKER SIZE

KW	VOLTS	AMPS	LUG SIZE
25	240 1Ø	125	#2 to 1/0
25	208 3Ø	100	#4 to 1/0
25	240 3Ø	90	#10 to 1/0

INSTALLATION LAYOUT

